

T5621 Series
T5721 Series
5 x 7 mm Surface Mount High Reliability
Tristate/Non-Tristate, 16KHz to 150MHz



Features

- Leadless chip carrier package is hermetically sealed for superior aging and field performance
- Crystal angle controlled to ± 1 minute for excellent temperature stability
- 168 hour Class B burn-in and extensive environmental testing for best performance in rugged field environments
- Start-up time <10 ms, typical
- Tristate option available
- Calculated MTBF is 3.8×10^6 hours at 125°C

Application

- Surface Mounted PCB projects requiring high reliability HCMOS clock waveforms

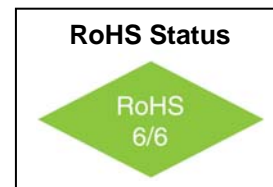

Description

These high reliability oscillators provide HCMOS clock waveforms for applications subjected to the most stringent environmental conditions. They are mechanically robust and weigh less than 0.2 grams. This 5x7mm SMD package has a hermetic seal, thus ensuring the integrity of each oscillator. Each oscillator is burned-in at 125°C for 168 hours, temperature cycled and centrifuged then fully tested in accordance with Table 1. Reliability tests are performed per Table 2. The calculated MTBF is 3.8×10^6 at 125°C.

Electrical Specifications

Parameter	Symbol	Condition	Min	Typ	Max	Unit	Note
Frequency Range	F		0.0016		100	MHz	
Frequency Stability	$\Delta F/F$	Vs. Operating Temperature	± 25		± 75	ppm	See Chart
		Aging 1 st Year After 1 st Year			± 3 ± 1		
Operating Temperature Range	T		-55°		+125°	°C	See Chart
Input Voltage	V _{cc}		4.5	5.0	5.5	V	
Input Current	I _{cc}			20	35	mA	
Waveform Symmetry		Measured at 50% V _{DD}		40/60	60/40	%	
Rise / Fall Time	T _r /T _f	<10MHz ≥10MHz		5 2	15 5	ns	0.8 to 2.4 volts
Output Level	“Zero” Level	Sinking 16mA	4.5		0.5	V	
	“One” Level	Sourcing 10mA					
Input requirement for pin.1		Output enable - Output disable (Tristate)	pin 1 may float or 2.8V min(sourcing 400 uA) pin 1 requires 0.4V max (sinking 400 uA)				



T5621 Series
T5721 Series
5 x 7 mm Surface Mount High Reliability
Tristate/Non-Tristate, 16KHz to 150MHz



Environmental and Mechanical Conditions

Parameter	Condition
Shock	MIL-STD 883, Method 2002, Test Condition B (1500 peak g, 0.5 ms duration, 1/2 sine wave, 5 shocks in 6 planes)
Vibration	MIL-STD 883, Method 2007, Test Condition A (20-2000Hz of .06: d.a. or 20 Gs, whichever is less)
Humidity	Resistant to 85° R.H. at 85°C
Leak	MIL-STD-883, Method 1014, Cond. A1 and C1
Case	Hermetically sealed ceramic LCC
Pads	60 microinch of gold over nickel
Resistance to Solvents	Per MIL-STD-202, Method 215
Marking	Epoxy ink or laser engraved

FIXED OUTPUT	TRISTATE	Operating Temperature	Frequency Stability
Model	Model		
T5621	T5721	-55°C to +85°C	±25 ppm
T5622	T5722	-55°C to +85°C	±50 ppm
T5623	T5723	-55°C to +125°C	±75 ppm
T5624	T5724	-55°C to +125°C	±50 ppm

Table 1

Each unit undergoes the following:

- | | |
|--|---|
| 1. Stabilization Bake | MIL-STD-883 Method 1008, Cond., B |
| 2. Temperature Cycling | MIL-STD-883 Method 1010, Cond, B |
| 3. Constant Acceleration | MIL-STD-883 Method 2001, Cond, A |
| 4. Burn-in | MIL-STD-883 Method 1015, Cond B (125°C for 168 hours with bias) |
| 5. Fine Leak | MIL-STD-883 Method 1014, Cond. A1 |
| 6. Gross Leak | MIL-STD-883 Method 1014, Cond C |
| 7. Electrical Test at 25°C and temperature extremes, as follows: | |
| A. Frequency | F. Duty Cycle |
| B. Current | G. Frequency at 5.5V |
| C. Rise Time | H. Frequency at 4.5V |
| D. Fall Time | I. "Zero" logic level |
| E. Duty Cycle | J. "One" logic level |
| K. Tristate | |

Test Data on each unit is available for additional cost

Thermal Characteristics

Thermal Resistance

From Junction to Case, R_{θjc} 16 °C/Watt

Surface Mount Application

These packages are designed for reflow soldering in accordance with recommended profiles. For hand-soldering, the temperature of the iron should not exceed 400°C for three seconds.



T5621 Series
T5721 Series
5 x 7 mm Surface Mount High Reliability
Tristate/Non-Tristate, 16KHz to 150MHz

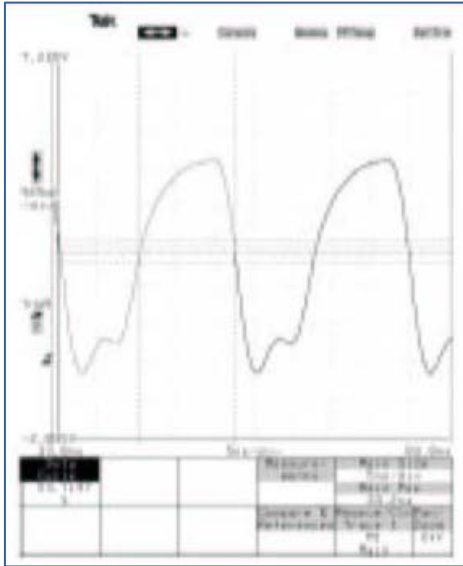

Fig.1 T5322-20M with 25pf load

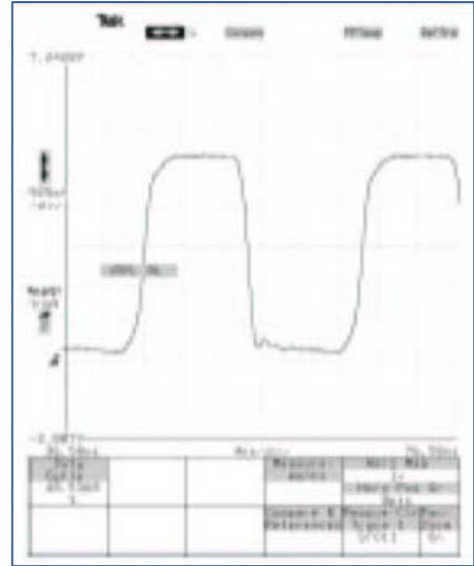
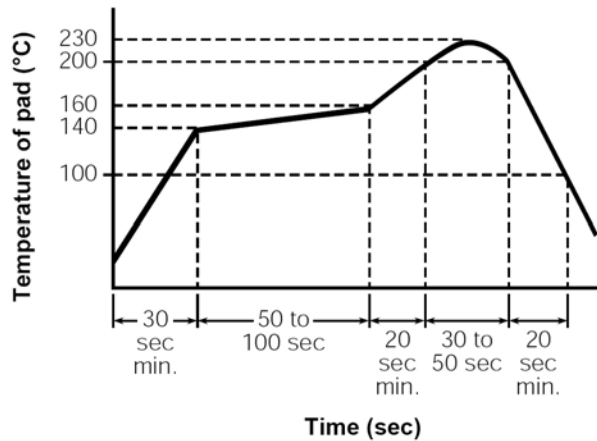
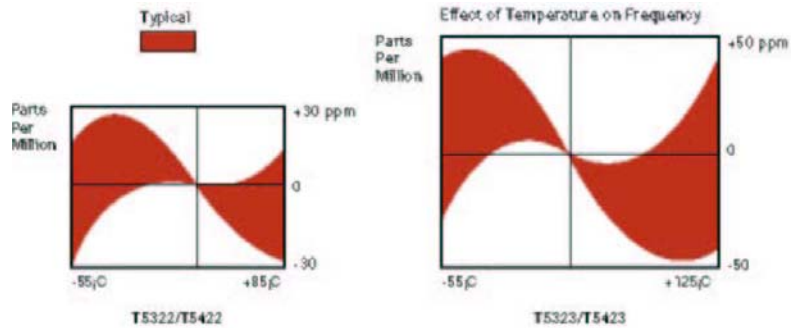

Fig.2 T5322-20M without load



Recommended Reflow Soldering Profile



T5621 Series
T5721 Series
5 x 7 mm Surface Mount High Reliability
Tristate/Non-Tristate, 16KHz to 150MHz



PROCESSING FLOW CHART

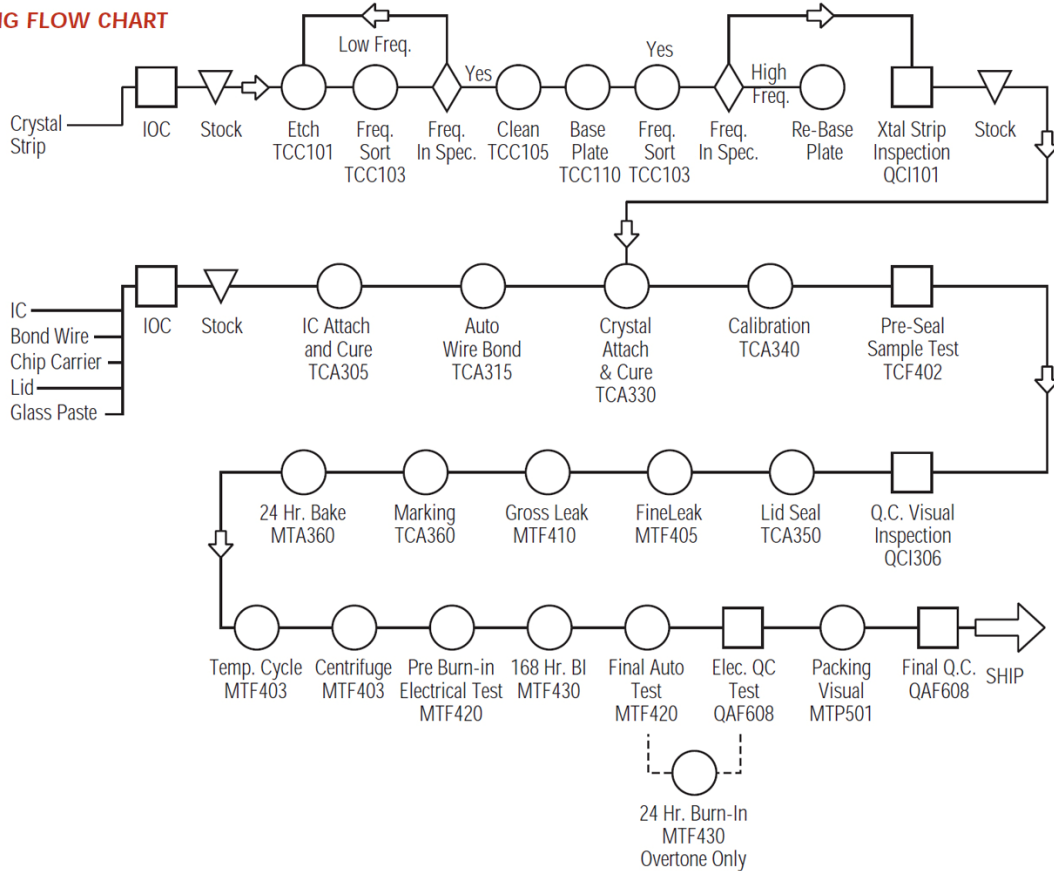

T5621 Series
T5721 Series
5 x 7 mm Surface Mount High Reliability
Tristate/Non-Tristate, 16KHz to 150MHz



TABLE 2
Reliability Test Procedures and Conditions for Quartz Crystal Oscillators

1. Group A

Electrical Characteristics at -55°C, 25°C and 125°C
 (85°C for T5622 and T5722)
 Frequency @ 4.5, 5.50 and 5.5 volts
 Symmetry (Duty Cycle)
 Input current
 Zero/One levels
 Rise/Fall times
 Physical Dimensions
 Length/width
 Height
 Package finish (Corrosion, discoloration, etc.)
 Marking placement/legibility

2. Group B- Life Test

1000 hrs at or above 125°C, 5.0 VDC, with proper load

3. Group C- All units have passed Group A testing

A. Subgroup 1-8 pcs.

<u>Standard</u>	<u>Condition</u>	<u>Description</u>	<u>End Point Measurement</u>
MIL-STD-883	Method 2002 COND.B	Mechanical Shock 1500 g's, 0.5ms 5 drops, 6 axis	Frequency Output waveform
MIL-STD-883	Method 2007 COND. A.	Vibration, var. freq. 20 g's, 0.06" disp., 20- 20, 000-20 Hz	Frequency Output waveform
MIL-STD-883	Method 2003	Solderability	Visual 95% Coverage

B. Subgroup 2-4 pcs (One-half of Subgroup 1)

<u>Standard</u>	<u>Condition</u>	<u>Description</u>	<u>End point Measurement</u>
MIL-STD-883	Method 1011 COND. B	Thermal Shock Liq. To liq. -55°C to 125°C, 15cycles	Frequency Output waveform
MIL-STD-202	Method 105 COND. B	Altitude, 3.44 inch Hg. 12 hrs	Frequency Output waveform
MIL-STD-883	Method 1004	Moisture resist. with 3.3V applied 25°C to 65°C, 90 to 100% RH, 10 cycles	Frequency Output waveform
MIL-STD-202	Method 210 COND.A	Resistance to Solder Heat Immersion @350°C 3.5 sec	Frequency Output waveform

C. Subgroups 3-4 pcs. (One half of Subgroup 1)

<u>Standard</u>	<u>Condition</u>	<u>Description</u>	<u>End point Measurement</u>
	Storage Temp. No. Oper	24 hrs. @ -55°C 24 hrs. @ 125°C	Frequency Output waveform
MIL-STD-883	Method 1009 COND. A	Salt Atmosphere 24 hrs. @ 35°C 0.5-3.0% Solution	Frequency Output waveform Visual
MIL-STD-883	Method 1014 COND. A1	Fine Leak	Qs <5 X10 ⁻⁸
MIL-STD-883	Method 1014 COND. C1	Gross Leak	Visual in 125°C Detector fluid

